





AM-PRO-0008 – Loss Factor Calculation Procedure

Asset Management – Network Assets

DOCUMENT NO.	AM-PRO-0008	VERSION NO.	1.0
DATE	30 Jul 2020		
SECURITY CLASS	Public – Social Media		
REVIEW CATEGORY	2 Years - Low Risk	REVIEW DUE	31 Jul 2022

Approvals

CREATED BY:	Jin Lo Network Assets Engineer	18 Jun 2020	 SIGNATURE
APPROVED BY:	Anton Booyzen GM Asset Management	30 Jul 2020	 SIGNATURE

Version History

VERSION	APPROVED BY	DATE
1.0	GM Asset Management	30-JUL-20

Version Change Table

VERSION	PAGE	PARAGRAPH	DESCRIPTION OF CHANGE
1.0	All	All	DMS 1206866_1, 1207066_1, 1206863_1 ported into new template, and methodology genericized to make ready for future load flow and data systems. Methodology updated to separate winter day, winter night, summer day, summer night losses Documentation updated with: <ul style="list-style-type: none"> simple explanation of loss factors outline of accuracy limits

Table of Contents

1. PURPOSE	4
2. SCOPE	4
3. REFERENCES	4
3.1 External References	4
3.2 Internal References	4
4. DEFINITIONS	5
5. OVERVIEW	7
5.1 Network Area and Points of Connection	7
5.2 Energy and Losses	7
5.3 Reconciliation & Loss Factor	8
5.4 Philosophy	8
6. METHODOLOGY	9
6.1 Calculation Records	9
6.2 Technical Losses – 33kV / 66kV Subtransmission	9
6.3 Technical Losses – 11kV / 22kV Distribution	10
6.4 Technical Losses – LV Distribution & Service Mains	10
6.5 Technical Losses - Generation	11
6.6 Losses – Time-of-Use (TOU) Customers	12
6.7 Technical Losses – Inter-Network Transfers	12
6.8 Non-Technical Losses	13
6.9 Unaccounted for Energy (UFE)	13
7. RECORDS	17
8. COMPLIANCE	18

Appendices

Appendix 1 – Factors that Affect Accuracy	14
Appendix 2 – Formulas	15
Appendix 3 – Loss Ratio	16

1. PURPOSE

This standard outlines the methodology used to estimate and predict losses for electricity that is conveyed over the distribution network.

Estimated losses are then converted to loss factors, which are used to estimate and allocate charges for energy losses (real and administrative) in the transmission and distribution of electricity to different users depending on where they are on the grid, their usage of electricity and the network.

2. SCOPE

The calculation of loss factors presented in this document apply to conveyance of electricity over the distribution network and service mains upstream of customer metering points only.

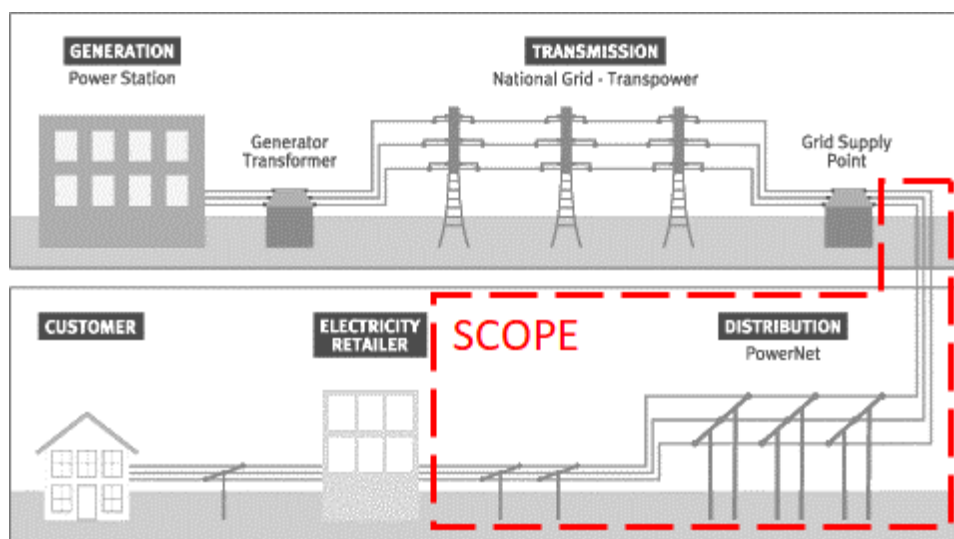

Figure 1 - Typical flow of electricity from generation to consumer – scope of study outlined

3. REFERENCES

3.1 External References

[Electricity Industry Participation Code 2010 - Part 15, Reconciliation, Electricity Authority](#)

[Electricity Act 1992 and subsequent amendments](#)

[Electricity Regulations 1997 and subsequent amendments](#)

[Guidelines on the Calculation and the Use of the Loss Factors for Reconciliation Purposes – Version 2.3, Electricity Authority](#)

3.2 Internal References

[AM-STD-0002 - Installation Connection Standard](#)

4. DEFINITIONS

Unless otherwise defined below, the terms used in this standard have meanings as defined in the Electricity Act 1992 and Electricity Regulations 1997 and subsequent amendments.

Code

Electricity Industry Participation Code

Consumer / Customer

The end users of electricity who are connected to the electricity network. Customers can range from residential households to large commercial operations.

Distributor

Distribution network companies own and manage the medium and low voltage networks which transport electricity to residential, commercial, and some industrial customers.

Electricity Meter

Means the certified equipment used to measure the amount of electricity conveyed.

Embedded generation

Electricity generation that is directly connected and injects energy into the distribution network (rather than via the transmission grid).

Fixed losses

Electrical losses that are independent of load levels. Predominately due to losses from transformer core energisation. Forms part of Technical Losses.

Also known as “iron losses” or “standing losses” or “no-load losses”.

Grid Exit Point (GXP)

The point of connection at which a supply of electricity may flow between the transmission network and the distribution network.

Installation Control Point (ICP)

The nominated point of connection, between the distribution network and the customer, at which electricity is deemed to be supplied to the customer.

Load

Electrical power drawn from the distribution network by consumers.

Loss Factor

A multiplier that is applied to metered electricity consumption over a period (e.g. annual or seasonal), to estimate the equivalent consumption information at energy injection points. Used to account for losses in the conveyance of electricity to that metered consumer.

Mains

The cable or wiring of the Installation connecting between the Point of Supply and the main switchboard and/or Metering Point.

Metering Point

Means the location or locations in an installation where the metering equipment is installed.

Network Supply Point (NSP)

Point of connection at which electricity may flow between the distribution network and consumers or generators.

Non-technical loss factor

A loss factor that is used to account for the difference between reconciliation losses and technical losses due to inaccuracies in measurement, data handling, and energy theft.

PSS Adept

Network modelling, simulation, and load flow analysis software.

Reconciliation loss factor

A loss factor that represents the difference between the electricity delivered to consumers and the electricity injected into the network in order to supply the delivered electricity.

Retailer

Electricity retailers sell electricity to business and residential customers. Must have a valid Electricity Conveyance or Use of System Agreement with the distribution network.

Technical loss factor

A loss factor that is used to estimate the energy consumed by network equipment in the delivery of electricity to customers.

Transmission

Transpower transports electricity from generation stations through the National Grid to various grid exit points (GXPs) around the country.

Unaccounted for Energy (UFE)

The difference between reported energy injected into a network and the reported energy extracted from the network, after adjustments for estimated losses. UFE can comprise of differences between actual and estimated losses.

Variable losses

Electrical losses which are dependent on the quantity of electricity conveyed by the network. Generally due to electrical resistance of network assets. Forms part of Technical Losses.

Also known as “copper losses” or “load losses” or “ I^2R losses”.

5. OVERVIEW

5.1 Network Area and Points of Connection

Networks are divided into “study areas” bounded between injection and consumption meters.

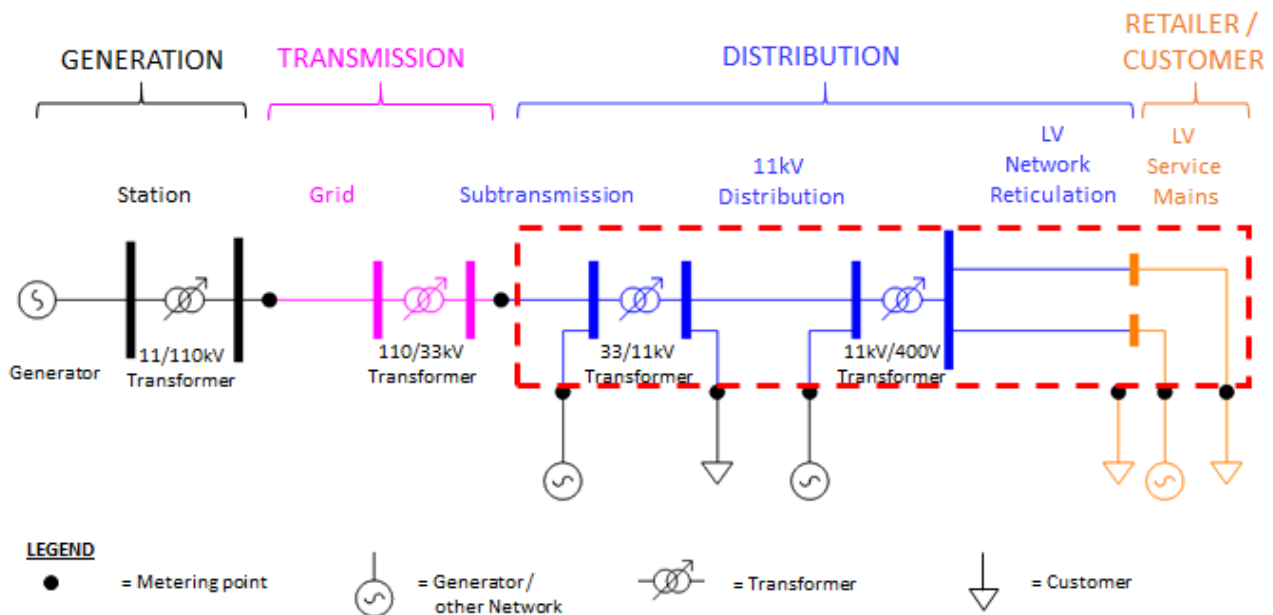

Figure 2 - Simplified view of conveyance of electricity – Typical distributor study area outlined in red

5.2 Energy and Losses

For any study area:

$$Energy_{injected} = Energy_{extracted} + Losses$$

$Energy_{injected}$ is the gross energy entering the study area from:

- embedded generators connected to the distribution network,
- inter-connections from other networks,
- or from generators via the transmission grid

$Energy_{extracted}$ is the net energy delivered or exiting the study area to:

- customers connected to the distribution network,
- inter-connections to other networks,
- or to the transmission grid

5.3 Reconciliation & Loss Factor

In the practical functioning of the NZ electricity market, this is broken down to:

$$\begin{aligned} \text{(Reported) Energy}_{\text{injected}} &= \text{(Reported) Energy}_{\text{extracted}} + \\ &\quad \text{(Estimated) Technical Losses} + \\ &\quad \text{(Estimated) Non – Technical Losses} + \text{UFE} \end{aligned}$$

Where:

$$\text{Estimated Losses} = (\text{Loss Factor} - 1) * \text{(Reported) Energy}_{\text{injected or extracted}}$$

$$\text{Estimated Technical Loss} = \text{No load losses (Fixed)} + \text{Load Losses (Variable)}$$

$$\text{Estimated Non – Technical Loss} = \text{Reconciliation Loss} - \text{Technical Loss}$$

Reconciliation of purchase volumes from injection points and sales volumes at customer metering points, occurs between the electricity retailers and NZ electricity market reconciliation manager at the end of each trading month (called a “wash-up”).

5.4 Philosophy

Efficient and practical loss allocation is achieved by grouping consumers with similar demand profiles and shared network assets in loss calculations. Each network is divided into areas for separate study. These are commonly defined by GXP and NSP metering.

Large time-of-use (TOU) customers and their consumption / generation are separated from typical profile customer groups and have separate loss calculations (per EA guidelines, defined as individual customers with greater than 10MW demand, or embedded generation with more than 10MW nameplate rating)

The normal state of the network is used in calculations. Temporary alternative configurations are assumed to have minimal effect on losses over the period of consideration. Longer term alternative configurations (e.g. over days) are excluded from calculations.

Technical losses, fixed and variable, are estimated separately for each:

- Portion of the study area: Subtransmission, Distribution, LV reticulation, and the portion of the customers’ service mains upstream of the meter.
- Time period: Summer Day, Summer Night, Winter Day, Summer Night defined as:

Winter Day	May to September inclusive	0700 - 2300 hours
Winter Night	May to September inclusive	2300 - 0700 hours
Summer Day	October to April inclusive	0700 - 2300 hours
Summer Night	October to April inclusive	2300 - 0700 hours

6. METHODOLOGY

6.1 Calculation Records

The calculations are done in PSS Adept and Excel and results recorded in spreadsheets.

Sales and purchases from multiple complete trading years are used in calculations. A single year may have insufficient data to represent typical future years, and may contain calculation error or measurement inaccuracy that has not been reconciled through a “wash-up”.

6.2 Technical Losses – 33kV / 66kV Subtransmission

Variable Losses

The complete subtransmission network is modelled manually in PSS Adept.

Substation loads are set equal to maximum demands for the previous three years. Each substation load is modelled in service with all other substation loads out of service. The peak loading in each network branch is recorded for each scenario.

Total loading for each network branch is determined as the sum of loading due to each individual substation load (load superposition). Similarly, superposition theory is applied if there are multiple sources of supply feeding the zone substations.

All substation loads are modelled in service together and peak losses in each network branch are recorded.

For each network branch the percentage of total loading attributable to each substation is used as the percentage of the total modelled peak losses attributed to that substation.

For each substation, total losses attributable to that substation are calculated as the sum of the losses in all branches attributed to that substation.

The average substation load is taken as the sum of the individual feeder’s average loading as extracted from SCADA data.

A loss ratio for each substation is calculated as the square of the substation load factor (load factor being the ratio of average demand to maximum demand). See Appendix 3.

Average losses for each substation are then calculated as the product of the total peak losses attributable to that substation and the loss ratio for that substation. See Appendix 2 for use of loss ratio to obtain average losses from peak losses.

Fixed Losses

Data on power transformer electrical characteristics is extracted from network records or manufacturer provided documentation where available. Where this is unavailable, data from similar transformers is substituted as estimates.

Fixed losses for subtransmission are the sum of all power transformer fixed losses.

As per EA guidelines capacitor, insulation dielectric and minor network equipment are excluded from calculations.

6.3 Technical Losses – 11kV / 22kV Distribution

Variable Losses

Each 11kV / 22kV distribution feeder is modelled in PSS Adept. Feeders are exported from GIS to create a PSS Adept model file.

Transformers are modelled as loads equal to the transformer rating scaled so that the modelled feeder current equals the peak current as extracted from SCADA data, to give an estimate of current load distribution on the feeder.

Expected future loads are added to the models. Predicted demand is based on received connection applications and projections of underlying load growth in the study period.

Peak losses on the feeder are determined for each network feeder.

A loss ratio for the feeder is calculated as the square of the substation load factor with load factor being the ratio of average feeder current to maximum feeder current. The average and maximum currents for the feeder are extracted from SCADA data.

Average losses are calculated as the product of the peak losses and the feeder loss ratio.

11kV / 22kV variable losses for each network are the sum of average losses on all feeders of the network.

Fixed Losses

11kV and 22kV distribution transformer fixed losses are based on standard losses for the transformer capacity rating.

Standard fixed losses data is supplied by manufacturer provided documentation where available. Where data on legacy distribution transformers is unavailable, data from similar transformers is substituted as estimates.

The number of transformers for each rating is extracted from GIS.

Fixed losses for 11kV / 22kV distribution are the sum of all distribution transformer fixed losses.

6.4 Technical Losses – LV Distribution & Service Mains

Typical LV circuits are modelled based on average circuit parameters and customer groupings. Complete LV circuits are not modelled due to practical limitations of calculation time, completeness of data on legacy network characteristics and individual customer usage.

Typical LV network models are created from average distribution transformer sizes, average number of customers per distribution transformer, and average conductor lengths and impedances. Data is extracted from GIS, Maximo, and ICP database.

Average customer LV service mains characteristics are estimated from average proximity to Point of Supply and construction standards. Modelled service mains length is a rough estimate based on approximate meter location, which can differ greatly to reality.

Typical LV network conductors are modelled as

- Squirrel for overhead LV network; and
- 3 core 95mm² Aluminium for underground LV network;

Typical LV service mains are modelled as

- 1 core 16mm² Copper

Peak losses for each circuit are modelled at peak load with all connections set to an estimated After Diversity Maximum Demand (ADMD) of 4kVA per residential customer.

An average LV load factor is calculated as the average of 11kV / 22kV feeder load factors.

Average losses are calculated as the product of peak losses and the square of the load factors (loss ratios) for each network model.

Average load is calculated as the product of peak load and the load factor for each network model.

Percentage losses are calculated for each model as the average losses per average load. These percentages are applied to the network models to determine overall losses.

6.5 Technical Losses – Generation

The area of the network in which load flow is affected by the generation is modelled in PSS.

Generation export data is extracted from retailer supplied data for the financial year being analysed. This data is rounded into discrete values from zero generation to maximum generation in equal steps.

Loading data for the modelled network is extracted from SCADA for the same time period. This is rounded into discrete values from minimum load to maximum load in equal steps.

Each possible combination of the discrete generation and loading levels is modelled to determine losses. Results are recorded in a reference table with losses for each discrete generation-loading scenario.

For each half hour period of the year, the difference in losses is calculated as the loss value from the reference table (based on the combination of generation and network loading for that half hour period) minus the losses expected if there was no generation (value from the reference table with generation at zero and network loading at the value for that half hour period).

Percentage loss difference is calculated for each time period, as the loss difference divided by the generation for that half hour period (unrounded).

The overall loss factor is taken as one plus the average of the percentage losses for each half hour period of the year.

6.6 Losses – Time-of-Use (TOU) Customers

The network supplying each TOU customer grouping is modelled in PSS Adept.

Banding & Loss Allocation

TOU customer group load profiles are separated into nine discrete percentile bands. Individual TOU customers are then grouped in relevant band according to its total % variable losses. Band % losses are determined by dividing sum of total losses from sum of average demand in each band.

Average demand is calculated from individual total energy reading kWh divided by number of hours in a year.

Total technical losses is the sum of attributable transformer fixed losses, distribution variable losses and subtransmission variable losses.

Technical loss factors are allocated according to the average demand of the individual customer within their band.

Non-technical loss factor is assumed to be the same for all TOU customers.

Variable Losses

Subtransmission variable losses are determined by dividing individual average demand from its relevant subtransmission average load, multiplied by relevant total average losses.

Distribution variable losses are determined by dividing individual proportional variable losses by the sum of proportional variable losses from all bands, multiplied by the sum of all TOU assigned average losses.

$$\text{proportional variable losses} = \text{demand}_{max}^2 \times \text{distance}_{to\ substation}$$

Total % variable losses are determined by dividing individual total losses from its average demand.

Fixed Losses

Transformer fixed losses attributable to each customer is allocated according to the proportion of load to transformer utilization.

6.7 Technical Losses – Inter-Network Transfers

Allocation

The loss factors applied to metering at inter-network transfers differ from those calculated in previous sections as they are used to reconcile the energy entering the network.

The metering installed at the transfer point captures the energy transferred between the networks which is then subtracted from the network accepting the transfer and added to the network from which the load is normally supplied. This is done after metering data is corrected with the loss factor.

The loss factor accounts for the increase in losses on the network accepting the transfer (including losses on the area of network transferred), so that these are included in the energy reconciled back to the network from which the load is transferred. This ensures the network accepting the load transfer does not have its measured losses increased due to providing this backup supply.

All losses are accounted for as the difference between metered energy entering the networks and metered consumption on the networks. The loss factor determines which network (customers) the losses are allocated to.

Loss Calculation

A model is created for the network to which the load is transferred and which is affected (load flow altered) by this extra load as well as the area of network being transferred.

Feeder loads are scaled to the peak level indicated by SCADA data for the feeder.

The full feeder from which the load is transferred may also be modelled so that the appropriate consumption level may be estimated. This is done by group scaling loads on the feeder to the peak consumption level indicated by SCADA data for the feeder. However, the part of the feeder not transferred is not included in modelling losses.

Peak losses are obtained from this peak load model under the normal network configuration and then under the temporary transfer configuration. The difference in losses between these configurations is the extra losses which are added to the transfer metering via the loss factor.

The average losses are then calculated as the product of the peak losses and loss ratio for the transferred load.

The loss factor is calculated as one plus the average losses divided by the average load of the transferred load.

Transfers may be bi-directional so separate models and calculations must be completed to determine different loss factors to be applied to the metering depending on the transfer direction.

A default loss factor of one is applied where reverse transfers are not possible or very rare.

6.8 Non-Technical Losses

By nature, the individual components of non-technical losses, measurement errors, data handling errors (by retailers, distributors or reconciliation manager), energy theft, faulty equipment etc. are difficult to estimate.

Aggregate non-technical losses are defined as:

$$\text{Non – technical loss} = \text{Reconciliation Loss} – \text{Technical Loss}$$

Non-technical losses are allocated proportionally to the customer's relative demand in the study area. This contrasts with technical losses which are proportional to the square of demand.

6.9 Unaccounted for Energy (UFE)

Differences between estimated and real losses for the trading period manifests as UFE. Occurrence of UFE is inevitable due to accuracy of sales and purchases data, and the estimate nature of losses used in the calculation.

$$\text{UFE} = (\text{Reported}) \text{Energy}_{\text{injected}} – (\text{Reported}) \text{Energy}_{\text{extracted}} – (\text{Estimated}) \text{Technical Losses} \\ – (\text{Estimated}) \text{Non – Technical Losses}$$

Negative UFE indicates overestimation of losses, and/or overstatement of volumes purchased, and/or understatement of volumes sold. The corollary is true for positive UFE.

Appendices

Appendix 1 – Factors that Affect Accuracy

Loss factor estimation is a very time intensive exercise, requiring processing of large volumes of data (e.g. in extreme adherences to 'user-pays' philosophy, calculations are done for every half-hour period for every customer at every point in the network).

The supposed benefits of more accurate loss estimation become easily overwhelmed by the costs in practical implementation of such a system for large numbers of small customers. Normally, the time taken is reduced through a number of assumptions:

- Grouping of similar customers with similar network characteristics.

Loss factors are essentially a prediction of losses based on past consumption and generation patterns. Differences between real and estimated losses arise due to a number of technical factors:

- Differences in predicted and actual consumption load profile
- Differences in predicted and actual generation profiles
- Large network configuration changes that change real losses
- Meter accuracy
- Meter data completeness. E.g. legacy installations do not have voltage and power factor measurement
- Data input from SCADA from non-metering class instrument transformers
- Harmonic measurement and induced losses
- Reactive power data
- Electrical resistance of materials vary with temperature, changing the real losses
- Electrical resistance of contact points can deteriorate over time. Mostly minimal, however, may be non-trivial when considered over the whole distribution network.

Additionally, there are a large number of information management and transactional factors that also affect accuracy:

- Lack of half hourly sales data. Aggregation of purchase and sales data over larger time periods obfuscates the peak loading on the network. As losses are a function of the square of load, underestimation of peaks has a larger effect on estimated losses.
- Data handling errors from the distributor or retailer
- Data reporting lag and data obfuscation
- Openness of data trading between retailers and distributors.

Rights to information and privacy concerns are also obstacles to accurate loss calculation:

- Possible right of refusal to smart meter installation
- Ownership boundaries which prevents knowledge of service main conductor attributes e.g. length of conductor between the boundary and customer meter. For rural networks, this will have a larger influence on the losses at LV due to the variance in conductor impedance.
- Embedded Generation, although there is low penetration at the moment, have large influence on losses, especially at LV level.

Appendix 2 – Formulas

Load Losses of the sub-transmission and distribution network can be calculated using the following equations:

$$\text{Load Energy Losses}(kWh) = \text{Load Losses}(kW) \text{ at Max Rating} \times (UF \%)^2 \times LLF \times TH \text{ (hrs)}$$

Load Loss Factor (LLF): The ratio between average load loss and peak load loss, which uses half-hour data. Load loss is proportional to the square of the current. $P_{loss} = I^2 R$

$$LLF = \frac{\sum_{n=1}^{THH} \left(\frac{\text{Load}_n^2}{\text{PeakLoad}^2} \right)}{THH}$$

Utilization Factor (UF) is the ratio between the peak load (kVA) and the rated capacity of a transformer.

$$UF = \frac{\text{Peak Load}}{\text{Rated Capacity}}$$

$$\text{Losses} = \text{No Load Losses} + \text{Load losses}$$

No-load losses for Power Transformer and Distribution Transformer were obtained from manufacture data.

$$\text{No Load Losses}(kWh) = \text{No Load Losses}(kW) \times TH \text{ (hrs)}$$

The no-load loss of the power transformer is shared if the zone substation has multiple feeders owned by a different network. For example, in Racecourse Road Zone Substation, feeders 5 and 13 are owned by TPC, and feeders 6-12 are owned by EIL. The No-Load Losses of the Power Transformer will be proportional according to the average loading of each feeder to avoid double counting.

$$\text{Loss}(MWh) = \text{Purchase}(MWh) - \text{Sales}(MWh)$$

$$\text{Loss}(MWh) = \text{Technical Loss}(MWh) + \text{Non Technical Loss}(MWh)$$

$$\text{Technical Loss Factor} = 1 + \frac{\text{Technical Loss}}{\text{Technical Loss} + \text{Sales}}$$

$$\text{Non – Technical Loss Factor\&LV} = 1 + \frac{\text{Non – Technical Loss\&LV}}{\text{Technical Loss} + \text{Sales}}$$

$$\text{Overall Loss Factor} = \frac{\text{Purchase (MWh)}}{\text{Sales (MWh)}}$$

Appendix 3 – Loss Ratio

Due to the square law average losses for a network are not able to be determined from modelling the network at average loading. Instead the network is modelled at peak loading to determine peak losses which are then scaled by a loss ratio to get average losses. Below is the derivation of the loss ratio, describing the relationship between peak and average losses which is used in the calculation of network losses;

$$Losses = I_{line}^2 R_{line}$$

$$I_{load} = \frac{P_{load}}{V_{load}}$$

$$I_{load} = k_0 P_{load}$$

$$\text{where constant } k_0 = \frac{1}{V_{load}},$$

and V_{load} assumed to be constant

$$I_{line} = k_0 P_{load}$$

$$\text{since } I_{load} = I_{line}$$

$$Losses = (k_0 P_{load})^2 R_{line}$$

$$Losses = k_0 P_{load}^2$$

where constant $k = k^2 R_{line}$, R_{line} assumed to be constant

$$\frac{Losses_{average}}{Losses_{peak}} = \frac{k P_{average\ load}^2}{k P_{peak\ load}^2}$$

$$\frac{Losses_{average}}{Losses_{peak}} = \frac{P_{average\ load}^2}{P_{peak\ load}^2} Losses_{peak}$$

constants cancel

$$\frac{Losses_{average}}{Losses_{peak}} = \left(\frac{P_{average\ load}}{P_{peak\ load}} \right)^2 Losses_{peak}$$

$$Losses_{average} = (Load\ Factor)^2 Losses_{peak}$$

$$Load\ Factor = \frac{P_{average\ load}}{P_{peak\ load}}$$

$$Losses_{average} = LossRatio \times Losses_{peak}$$

$$LossRatio = LossFactor^2$$

7. RECORDS

INPUT DATA	DESCRIPTION	SOURCE
Total Purchases		Retailer reports via PowerNet Commercial Services
Total Sales		Retailer reports via PowerNet Commercial Services
NSP Total Sales	Total Consumption	Retailer reports via PowerNet Commercial Services
TOU Customers	Total & Peak Consumption	Retailer reports via PowerNet Commercial Services & ICP Database
Subtransmission Models		System Diagrams – Models manually created in PSS Adept
Substation Loads	Average & Peak Amps	SCADA
11kV Feeder Models		GIS-PSS Adept Extraction
11kV Feeder Loads	Average & Peak Amps	SCADA
LV Models	Network & Service Conductor Attributes	GIS Report – Average LV models manually created in PSS Adept
LV Loads	Average & Peak Amps	Commercial Services & ICP Database
Transformer Population		GIS Report, Maximo Report
Power Transformer Electrical Characteristics	Per Individual Unit	Transformer name plates, manuals, test records, estimation
Distribution Transformer Electrical Characteristics	Typical	Transformer manuals, manufacturer information, estimation

Notes on data from SCADA

- SCADA records the current measured at the circuit breakers of each feeder, sampled at 10 minutes intervals. Note that true peaks may not be reflected in the data.
- The data is averaged in sets of three to obtain half hour intervals.
- This data is plotted and any unusual levels and variations (such as tie shifts) are manually excluded when typical network behaviour profiles are required.
- Input into SCADA is from non-metering class instrument transformers. Data from SCADA, therefore, will not have the same accuracy range as metering class instrument transformers used for sales and purchases.

